



## Prescribing Requirements and Considerations for Medical Necessity

Thank you for your interest in Cala kIQ™, a TAPS (Transcutaneous Afferent Patterned Stimulation) next generation FDA-cleared wearable neuromodulation therapy for action hand tremors. To prescribe the Cala kIQ System for your patient, the following documents should be completed and sent to Cala:

1. **Cala TAPS Therapy: Standard Written Order – Prescription Form**
  - Completed, signed, and dated
2. **Patient-signed intake form**
3. **A copy of the front and back of the insurance card**
4. **Electronically signed chart notes with patient name, date of birth, assigned sex at birth, and the following considerations for medical necessity**

---

**Diagnosis**

- Diagnosis of essential tremor (G25.0)
- Postural or kinetic tremors of hand(s) and which hand exhibits the tremor

**Tremor Impact & Limitations**

- Tremor has worsened over time (as assessed by treating physician in a face-to-face or telehealth visit to evaluate tremor amplitude) OR note tremor severity (e.g. moderate or severe)
- Tremor interferes with specified activities of daily living (ADLs) (e.g. eating, drinking, writing, bathing, hygiene, dressing)

**Prior Treatments & Physician Recommendation**

- Patient has had persistent tremor despite prior or concurrent use of one or more first-line pharmacologic agents (propranolol or primidone) OR first-line pharmacologic therapy is contraindicated or not tolerated for the patient
- Physician recommendation of TAPS therapy clearly documented for managing ADLs

After receiving the completed documents, our team is committed to providing patients the support they need throughout their treatment journey, from submitting reimbursement to using therapy.

If you or your staff have any questions or concerns about your patient's Cala kIQ prescription, please do not hesitate to contact our Customer Care team at 888-699-1009 or [CustomerCare@CalaHealth.com](mailto:CustomerCare@CalaHealth.com).

**We look forward to working together to provide the best possible care for your patient.**

---

Cala kIQ is indicated to aid in the temporary relief of hand tremors in the treated hand following stimulation in adults with essential tremor. Cala kIQ is indicated to aid in the temporary relief of postural and kinetic hand tremor symptoms that impact some activities of daily living the treated hand following stimulation in adults with Parkinson's Disease. Caution: Federal law restricts this device to sale by or on the order of a physician. Before use, refer to the product labeling for complete product instructions for use, contraindications, warnings, and precautions at [CalaHealth.com/Safety](http://CalaHealth.com/Safety). SD-20002 Rev C Jun 2023

**Submit completed forms via:** Fax: 1-833-230-9251 | Encrypted Email: [Intake@CalaHealth.com](mailto:Intake@CalaHealth.com) | Secure Upload: [CalaRx.com](http://CalaRx.com)  
Health Care Professional Line: 888-585-7101 | Cala Customer Care: 888-699-1009  
1800 Gateway Drive | Suite 300 | San Mateo, CA | 94404

Copyright © 2019-2023, Cala Health, Inc. All Rights Reserved. Cala Health, Cala, and Cala kIQ are trademarks of Cala Health, Inc., registered or pending in the U.S. and other countries.

## Measuring Wrist Size

Capturing an accurate measure of your patient's wrist is important to ensure proper fit of the Cala kIQ™ band for nerve targeting and therapy delivery. Cala provides a tool to help measure the patient's wrist size to input onto the prescription form (cm). A soft tape measure (tailor's tape, sewing tape, or paper measuring tape) may also be used. Please see the suggested approach below:

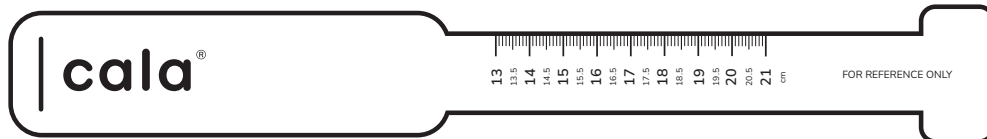

Position the measuring tool on the wrist as close to the hand as possible without impeding wrist movement. Should the patient have a prominent or protruding wrist bone, avoid measuring over it but rather measure proximal to the wrist bone.

Hold the measuring tool tight to the skin, but do not squeeze wrist. Measure where the top of the slit sits on the tool markings, (not where the end of the slit sits on the markings). Note the size in cm on the patient's prescription form. Cala will use this to ship the correct size band to your patient.

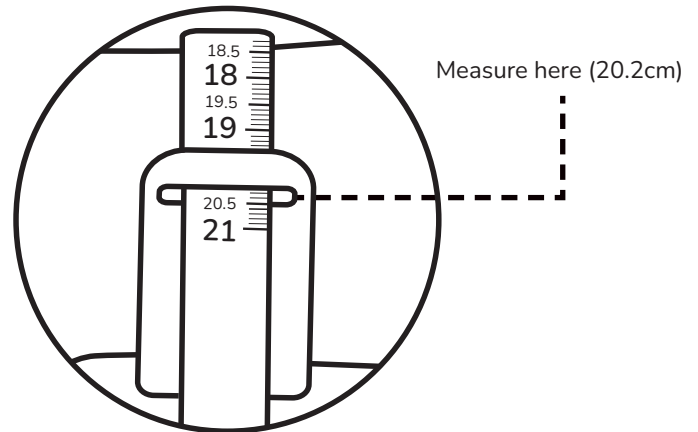
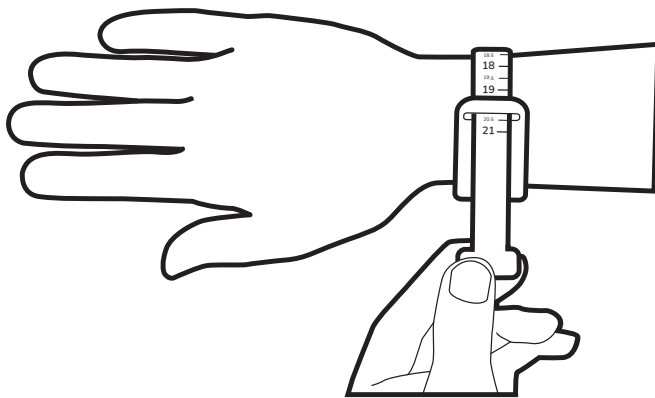

## Selecting a Tremor Task

The Cala kIQ System calibrates therapy to each patient's unique tremor physiology based on a postural hold called a "tremor task". It is important for the prescribing clinician to indicate on the prescription form which tremor task (**wing-beating** or **outstretched hold**) predominantly elicits the hand tremor.

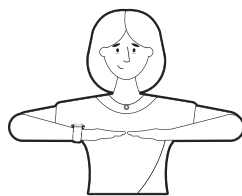

Wing-beating Postural Hold

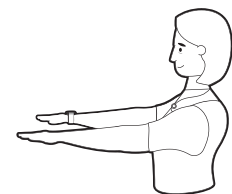
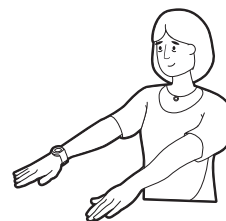

Outstretched Postural Hold

**CALA TAPS THERAPY: STANDARD WRITTEN ORDER—PRESCRIPTION FORM**

Cala Healthcare Professional Line: 1-888-585-7101	Submit completed forms via:
Cala Customer Care: 1-888-699-1009	Fax: 1-833-230-9251
Encrypted Email: <a href="mailto:Intake@CalaHealth.com">Intake@CalaHealth.com</a>	Secure Upload: <a href="https://CalaRx.com">CalaRx.com</a>

**PATIENT INFORMATION**

First Name:		Last Name:	
Date of Birth:		Sex: <input type="checkbox"/> Male <input type="checkbox"/> Female	
Address:		Email:	
City:	State:	Zip:	
Mobile Phone:		Home Phone:	

**PRESCRIPTION DETAILS (SELECT FROM EACH COLUMN)**

Wrist Measurement*	Tremor Task**	Cala Stimulator (K1018)	Cala Bands (K1019)	Length of prescription
_____ centimeters	<input type="checkbox"/> Outstretched <input type="checkbox"/> Wing Beating	Hand to treat: <input type="checkbox"/> Left <input type="checkbox"/> Right	Each band is a three-month supply = 3 billable units	<input type="checkbox"/> Lifetime (99) —OR— <input type="checkbox"/> Duration in Months _____

\* Please provide a measurement of the patient's wrist in centimeters. Using the measuring tool provided by Cala:

- Position the measuring tool on the wrist as close to the hand as possible without impeding wrist movement.
- Should the patient have a prominent or protruding wrist bone, avoid measuring over it but rather measure just proximal to the wrist bone.

\*\* The Tremor Task is a postural hold that helps characterize the patient's tremor.

- Please note which postural hold predominantly elicits the hand tremor.
- Most patients use the outstretched postural hold.

**Diagnosis ICD-10 Code (required):**

G25.000 Essential tremor

Other \_\_\_\_\_

**Confirmation:** Patient does not have any of these contraindications:

- Implanted electrical medical device, such as a pacemaker, defibrillator, or deep brain stimulator
- Have suspected or diagnosed epilepsy or other seizure disorder
- Pregnancy
- Swollen, infected, inflamed areas, or skin eruptions, open wounds, or cancerous lesions

**PRESCRIBER AUTHORIZATION**

This document serves as a Standard Written Order and Prescription for Cala TAPS Therapy for this patient. As this patient's physician, I attest that the clinical findings on this document accurately reflect the health information. I certify that the Cala TAPS Therapy is reasonable and medically necessary for the treatment of this patient. I understand that my email address may be required for me to access Cala TAPS Therapy data for this patient.

Prescriber's Signature:		Date:
First Name:	Last Name:	
NPI:	HCP: <input type="checkbox"/> MD/DO or <input type="checkbox"/> CRNP/PA	
Prescriber's Email:		
Practice Name/Institution:		Tax Id:
Practice Contact Name:	Practice Contact Phone:	
Practice Contact Email (if different from prescriber):		
Address:	Practice Fax:	
City:	State:	Zip:



# Cala Customer Care

## Patient Intake and Agreement Form

Submit completed forms via:

Fax: 1-833-230-9251

Encrypted Email: [Intake@CalaHealth.com](mailto:Intake@CalaHealth.com)

Secure Upload: [CalaRx.com](https://CalaRx.com)

Health Care Professional Line: 1-888-585-7101

Cala Customer Care: 1-888-699-1009

### 1. PATIENT INFORMATION

First Name:	Last Name:	
Date of Birth:	Gender: <input type="checkbox"/> Male <input type="checkbox"/> Female	
Address:	Email:	
City:	State:	Zip:
Mobile Phone:	Home Phone:	
Emergency Contact Name:	Emergency Contact Phone:	

### 2. INSURANCE INFORMATION

2a. Primary Insurance information			2b. Secondary Insurance Information		
Insurance Provider:			Insurance Provider:		
Policy ID	Group #:		Policy ID:	Group #:	
Address:			Address:		
City:	State:	Zip:	City:	State:	Zip:
Benefits Phone:			Benefits Phone:		
Policy Holder Name:			Policy Holder Name		
Policy Holder Date of Birth:			Policy Holder Date of Birth:		
Relationship to Patient: <input type="checkbox"/> Self <input type="checkbox"/> Spouse <input type="checkbox"/> Parent <input type="checkbox"/> Guardian			Relationship to Patient: <input type="checkbox"/> Self <input type="checkbox"/> Spouse <input type="checkbox"/> Parent <input type="checkbox"/> Guardian		

### 3. PATIENT AUTHORIZATION & AGREEMENT

I acknowledge that I have been provided with the following notices by accessing the company website or in writing (upon request) and understand notices may be revised from time to time:  
***Notice of Privacy Practices (HIPAA), Returns and Warranty, and Therapy Terms of Use which include the Patient Bill of Rights and Responsibilities, and Complaint Process.***  
 I agree to all applicable terms outlined in this document's Patient Acknowledgment and Financial Responsibility sections.  
 I, or my representative, will promptly notify Cala if I stop using Cala TAPS therapy for any reason or am hospitalized for more than 30 days.

 Patient Signature:	Date:
---	-------

Personal representative: If the individual signing this form is not the patient, please print name and specify relationship to the patient; if Power of Attorney, please provide documentation.

Personal Representative:	Date:
--------------------------	-------

#### 4. PATIENT ACKNOWLEDGEMENTS

- a. I authorize Cala and its staff to provide me with durable medical equipment prescribed by my healthcare professional (HCP). My HCP has explained the nature of this treatment, and I have received sufficient information about the Cala TAPS Therapy to make an informed decision.
- b. I authorize the release to Cala of any medical records for payment purposes, including but not limited to processing insurance claims. I also authorize Cala to share my medical records for healthcare operations and treatment purposes, including but not limited to sharing Cala TAPS therapy data with my prescribing HCP.
- c. My HCP has screened me for the appropriateness of Cala TAPS Therapy. I do not have a cardiac pacemaker, implanted defibrillator, insulin pump, other implanted electronic device, or implanted metal in the wrist. I am not pregnant or have been suspected or diagnosed with epilepsy or other seizure disorder. I understand the device should not be used on swollen, infected, inflamed areas, skin eruptions, open wounds, or cancerous lesions. I will alert my HCP and Cala if my health condition changes such that therapy use is now contraindicated.
- d. My HCP has explained the nature of this treatment, and I have received information about the Cala TAPS Therapy System and its appropriate and safe use. Upon receipt of my device, I understand that training is available to me by a Cala Customer Care Representative. I shall contact Cala Customer Care at 888-699-1009 Monday-Friday from 8 am – 7 pm Eastern, 5 am – 4 pm Pacific to schedule a training appointment.
- e. I take full responsibility for the safe use and care of the Cala TAPS Therapy System (which includes the Cala Stimulator, Base Station, and Band). I will advise my HCP before discontinuing treatment or using the equipment. I shall not hold Cala responsible for any adverse consequences related to any misuse, failure to use, or discontinuation of the treatment. Cala maintains customer support by telephone at 888-699-1009 Monday-Friday from 8 am – 7 pm Eastern, 5 am – 4 pm Pacific. If a treatment reaction occurs when an HCP is absent or outside of Cala business hours, I will stop using the Cala TAPS Therapy System immediately and contact Cala Customer Care or my HCP before resuming use. If a life-threatening medical emergency arises, I will contact my local emergency services number, such as 911, for assistance.
- f. **Medicare Beneficiary:** I understand the products and/or services provided by Cala are subject to the supplier standards contained in the Federal regulations shown at 42 Code of Federal Regulations Section 424.57(c). These standards concern business professional and operational matters (e.g., honoring warranties and hours of operation). The full text of these standards can be obtained at <https://www.ecfr.gov/current/title-42/chapter-IV/subchapter-B/part-424/subpart-D/section-424.57>. Upon request, I will be furnished with a paper copy of the standards.
- g. **Out-of-Network:** If Cala is out-of-network with my insurance, I understand that my insurance may not cover any items or services furnished by Cala. I understand I may seek care from another in-network provider. Cala will make reasonable efforts to inform me of my insurance coverage and estimated out-of-pocket expenses before delivery.
- h. **Results Not Guaranteed:** My HCP has prescribed Cala TAPS Therapy to deliver electrical stimulation to relieve hand tremor temporarily. I understand that this is not a cure for essential tremor. I also understand that individual patient results may vary, and no warranty or guarantee is made regarding my use of the Cala TAPS Therapy. I understand Cala TAPS therapy is intended for single patient use only and Cala Bands are provided with an initial three-month supply that must be replaced.
- i. **Return of Device to Cala: I understand that I cannot return any component of Cala TAPS Therapy for a refund unless the policy below permits.**
  - For All Medicare Patients (Parts B and C Advantage): I understand that the 60-day return policy does not apply when using Medicare benefits. Cala will collect copay fees monthly based on my ongoing use of Cala TAPS therapy. Upon termination of therapy use, I will no longer be charged copay fees, and Cala will stop billing Medicare on my behalf. If I stop using therapy, I will notify Cala (Returns@CalaTrio.com) and return all therapy components to Cala.
  - For Commercially Insured Patients: I understand that within 60 days of receiving my initial Cala TAPS Therapy, I can return all system components for any reason by writing to (Returns@CalaTrio.com) and returning the equipment except when insurance contract terms supersede this policy. Any deductible and/or out-of-pocket expenses are collected upon receipt of the Explanation of Benefits issued by the insurer as defined by the cost identified in the patient responsibility section of the EOB. Please see the “Limited Warranty” section regarding repair and replacement.
  - For 100% Self-Pay Patients: Within 60 days of receiving Cala TAPS Therapy, I can return all system components for any reason by writing to (Returns@CalaTrio.com) and returning the equipment. After receiving the returned equipment, Cala will void all agreements and refund credit card charges.
  - For Veterans Affairs Patients Only: Within 90 days of receiving Cala TAPS Therapy, I may return all the components for any reason by writing to Cala (Returns@CalaTrio.com) and returning the equipment. The VA will be refunded on my behalf for returned product that complies with this policy.

#### 5. PATIENT FINANCIAL RESPONSIBILITIES (NOT APPLICABLE TO VETERANS AFFAIRS PATIENTS)

- a. I assign to Cala all rights, benefits, and payments to which I am entitled under any benefit plan or insurance for items and services furnished to me or my dependents by Cala.
- b. Accepting items and services from Cala means accepting my responsibility for any deductible, copay, and remaining balance due. I authorize Cala to inquire about, submit and appeal claims to my insurance for items and services received from Cala.
- c. I authorize Cala to submit claims to my insurance on my behalf and my insurance to pay benefits directly to Cala. If I receive funds intended to pay, in whole or part, the forgoing claims, I will immediately pay over such funds to Cala to apply to any balance due.
- d. I may revoke this authorization in writing to Cala. I assign Cala any legal or administrative claim or cause of action, including fiduciary duty claims, arising from any benefit plan or insurance concerning medical expenses incurred from items or services received from Cala.
- e. I will promptly notify Cala of any changes to my insurance.
- f. I accept full and complete financial responsibility for all charges for any or all components of the Cala TAPS Therapy System that are not covered by my insurance or for which I am responsible for payment under my insurance. Cala accepts VISA, MasterCard, American Express, and Discover Card for payment.